

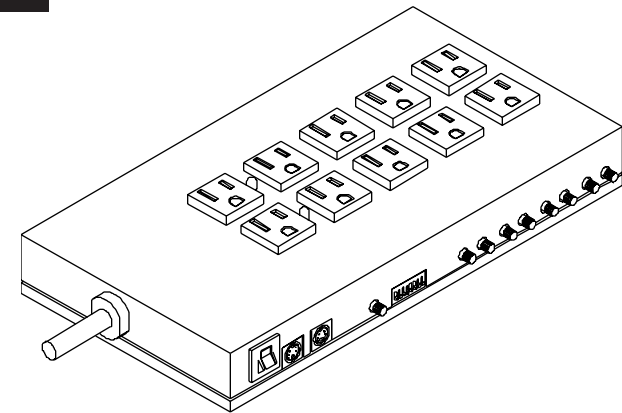

R.F. Systems - AC-8 Programmable Power Panel



Featuring:

Power Line Filtering and Surge suppression

2 Current Sensing Outlets

8 Switched Outlets

Turn Any Outlet On Continuously

Power Up and Power Down
Programmable Sequencing

Owners Manual



R.F. Systems, Inc.

303-604-6881

Thank you for selecting the R.F. Systems model AC-8 Power Panel

Safety Instructions

Read all instructions before connecting or operating the AC-8. Pay particular attention to the safety information. Keep this manual so you can refer to these safety instructions.

WARNING: There are no user serviceable parts inside. Refer all servicing to qualified service personnel.

WARNING: To reduce risk of fire or electric shock, do not expose the AC-8 to extreme heat, extreme cold, moisture or water. Do not allow foreign objects to get into the enclosure. If the unit is exposed to moisture, or a foreign object gets into the enclosure, immediately disconnect the power cord from the wall. Take the unit to a qualified service person for inspection and the necessary repairs.

Clean the AC-8 only with a dry cloth or a vacuum cleaner. Do not use water, solvents, or any other liquid to clean the AC-8.

Place the AC-8 on a fixed, level surface strong enough to support its weight. Keep the AC-8 away from heat sources such as radiators, heat registers, stoves, or any other appliance that produces heat.

The AC-8 may be operated only on 115 volt AC, 60 Hz power sources. Operating on any other power source may permanently damage the unit.

Connect the AC-8 to the power outlet only with the supplied 3-prong grounded power supply cord. The cable should be connected to a properly grounded 3-conductor wall outlet. Do

Specifications

Electrical

Input Power:	120 vac \pm 20% 50/60 Hz
Protection:	15 amp circuit breaker
I Power Consumption:	10 watts
Sensed Outlet Power:	450 watts max. per outlet
Switched Outlet Power:	1000 watts max. per outlet
Time Delays:	ON - .1 to 40 seconds OFF - 2 to 40 seconds
Operating Temperature:	0° to +50°C (+32° to +122°F)
Storage Temperature:	-40° to +80°C (-40° to +176°F)
External Link Trigger:	5 to 30vdc @ 10 mA max.

Noise and Surge Filter

Noise attenuation begins at 2 kHz with full attenuation at 200 kHz.

Max. Cont. AC Voltage:	130 vac
Max. Cont. DC voltage:	170 vdc
Peak Current:	13,000 amps (8x20 μ s)
Response Time:	< 5 nanoseconds
Maximum Clamping:	340 vac

Mechanical

Weight:	3 lbs.
Power Cord:	14AWG x 3Cond. 6 ft.
Outlets:	Three prong, grounded, polarized

All specifications subject to change without notice.



Trouble Checks

AC-8 does not activate when sensed device turns on

- Use the Sense Adjust to set the activation level of the AC-8 (see *Adjusting the AC-8* for details).
- Check to ensure the AC-8 is plugged in.
- Check A and B channel programming switches to ensure outlets are programmed correctly.
- Check Activate switches for proper programming.

External Link will not activate AC-8 channel

- Check to ensure the input signal is on the proper input pins of the external link connector.
- Check for proper polarity of trigger voltage (see *External Link*).
- Check to ensure the AC-8 is plugged in.
- Check A and B channel programming switches to ensure outlets are programmed correctly.
- Check Activate switches for proper programming.

The sensed devices do not turn on

- Check to ensure the AC-8 is plugged in.
- Check the circuit breaker on the AC-8. If it is popped, check for the cause and reset. DO NOT reset without finding the cause.

not modify the supplied cable in any way. Extension cords must be rated for adequate current.

Do not route the power cord where it can be crushed, pinched, bent at severe angles, exposed to heat, or damaged in any way. If the cord shows any sign of wear or damage, immediately stop using it and have the AC-8 serviced by a qualified service agency or from the R.F. Engineering service department.

If the AC-8 shows signs of improper operation, or if it has been dropped or damaged in any way, immediately disconnect the power cord from the power outlet. Take the AC-8 to a qualified service technician or send it directly to R.F. Engineering for inspection and the necessary repairs.



CAUTION: DO NOT REMOVE COVER.
NO USER SERVICABLE PARTS INSIDE.
REFER SERVICING TO QUALIFIED
SERVICE PERSONNEL.



The lightning flash with arrowhead symbol, within an equilateral triangle, is intended to alert you to the presence of uninsulated "dangerous voltage" within the product's enclosure that may be of sufficient magnitude to constitute a risk of electrical shock to persons.



The exclamation point within an equilateral triangle is intended to alert you to the presence of important operating and maintenance (servicing) instructions in the literature accompanying the appliance.

Table of Contents

Safety Instructions	i
Getting Started	1
Adjusting the AC-8	3
Adjusting Sequential Timing	4
Using the External Link	4
Trouble Checks	6
AC-8 does not activate when sensed device turns on .	6
External Link will not activate AC-8 channel	6
The sensed devices do not turn on	6
Specifications	7

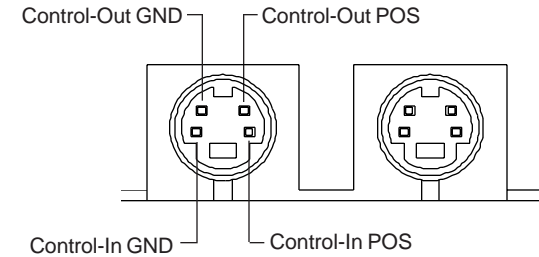

When the AC-8 sees a low signal (zero volts) on the **Control In** pin, the AC-8 will operate normally turning on only when the sensed device is turned on. When a high signal (1-33 volts) is on the **Control In** pin, the AC-8 will activate the channel just as if the sensed device had been turned on.

When an AC-8's channel is not active, the **Control Out** signal is low (zero volts). When the channel is activated through the sensed outlet or the incoming external link, this signal goes high (5 volts @ 15 mA). This control signal can then be used to activate external equipment.

NOTE: The External Control signals are electrically isolated, providing additional safety to the equipment connected to the External Control connectors.

Adjusting Sequential Timing

The AC-8 includes optional sequential timing for the activated outlets to allow each of the eight outlets to have a time delay on activate and de-activate. This allows for some equipment to be turned on prior to other pieces of equipment. This also allows for some equipment to turn off prior to other equipment. The turn-on and turn-off delay are individually programmed for each outlet.

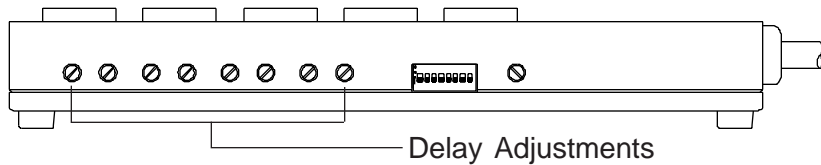

The **Delay On** and **Delay Off** adjustments are used to set the AC-8. Turning the **Delay On** clockwise will increase the delay of the activation of the outlet. Turning the **Delay Off** clockwise will delay the de-activation of the outlet. Each of these can be set to for up to 30 seconds of delay time. The adjustments are somewhat sensitive and care should be taken when trying to get the exact time delay.

Using the External Link

The AC-8 has two **External Link** connectors that provide a DC voltage interface to external equipment. The two connectors correspond to the A and B channels of the AC-8. External A is used with the A channel and the External B is used with the B channel. The pin designations for the connectors are listed below.

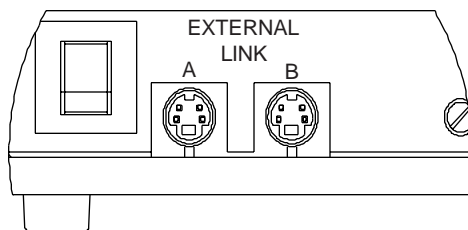

Getting Started

The AC-8 is a dual current sensing, programmable power switch that will detect when a device has been turned on and will then activate up to eight outlets for other equipment. The AC-8 can detect the status of two different devices with options for control from external signals. The AC-8 includes surge suppression and line filtering to help protect the equipment connected to it.

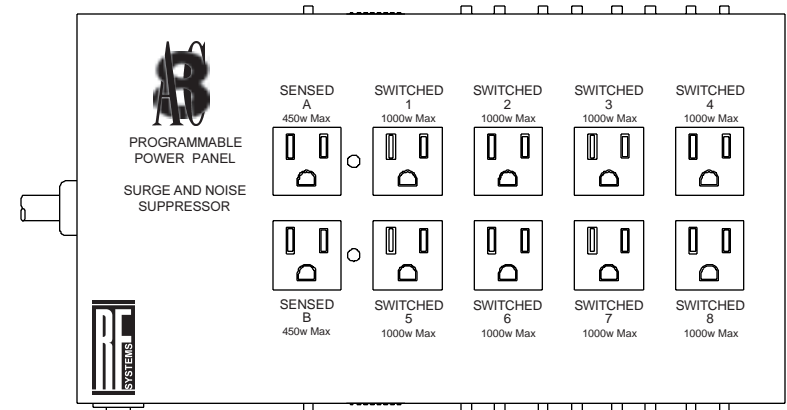

Installation Notes

The AC-8 power cord should be the first item connected.

The AC-8 is designed for maximum switching of 450 watts on the sensing outlets and 1000 watts on any single switched outlet. Exceeding these limits may result in permanent damage to the unit.

Programming the AC-8

The AC-8 is programmed by three banks of switches located on the side and end of the unit. The bank labeled **Program A** is used to program the A channel. The bank labeled **Program B** is used to program the B channel. The A channel corresponds to the device plugged into the A



sensing outlet and the A external link (see *Using the External Link*). The B channel corresponds to the device plugged into the B sensing outlet and the B external link. The bank labeled **Activate** will override both the A and B

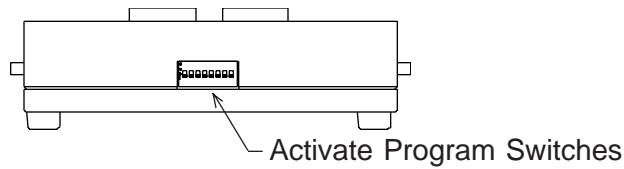
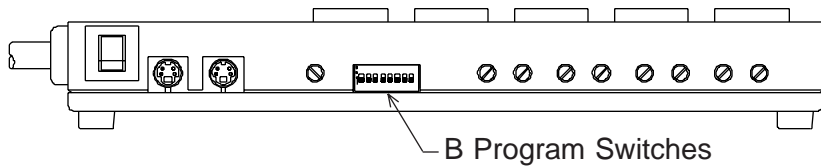
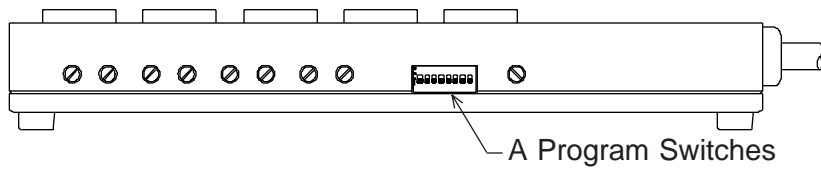

programming (see *Using the Activate Program*)

The switches have numbers that correspond to the outlet numbers 1 through 8. When a switch is turned ON, the corresponding outlet will be activated by the channel. When the switch is OFF, the corresponding outlet will not be activated by the channel. As an example: Program A has switches 1,2,3,7 turned ON. Program B has switches 3,4,5,6,7,8 turned ON. When the device plugged into sensing outlet A turns on, outlets 1,2,3 and 7 will then turn on. When the device plugged into sensing outlet B turns on, outlets 3,4,5,6,7 and 8 will turn on. As long as the sensed device is turned on, the programmed outlets will stay activated.

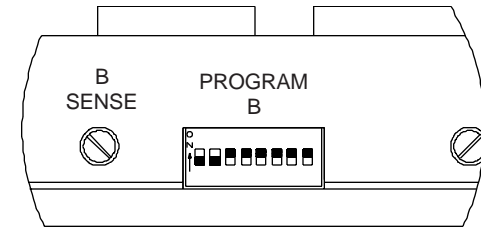
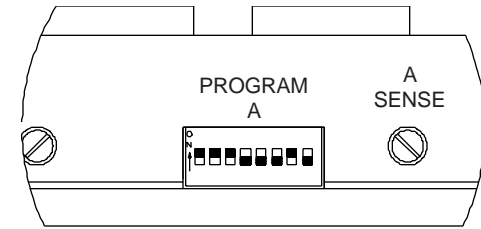

Adjusting the AC-8

The AC-8 allows for adjustment on the sensing outlets to overcome the standby current that most equipment will draw. This current is used to maintain memories and programming. The AC-8 must be able to distinguish between standby and operating modes of the sensed equipment. The **Sense Adjust** control for the A and B channels allows for this adjustment.

The Sense Adjust will increase sensitivity when turned clockwise and decrease sensitivity when turned counter-clockwise. Turn the **Sense Adjust** so that the programmed outlets (1-8) are not activated when the equipment in the sensed outlet is turned off (the sensed light will be off). Turn on the sensed equipment and the sensed light will turn on and the programmed outlets will activate. It may take several tries to get the adjustment correct. After this adjustment is made, there should be no need to change it in the future.