

DC Operation of the VI

The VI is designed to operate on 12 Vdc power. This allows it to be used in automobile and marine applications. By removing the wall transformer supplied and connecting the unit to 12 Vdc, the unit will run off the battery power. (NOTE: The VI has terminals inside the unit for connecting to power. Cutting the cord on the wall transformer will void the warranty).

Trouble Checks

No Output from the VI

- Check the wiring to ensure that all the connections are correct and that none of the lines are broken.
- Check wiring to ensure that neither input device is connected to the Video Out terminals.
- Check the input device to ensure it is working properly.

VI does not Switch to Video B

- Check the power to the VI.
- Check the connection on the Video B terminal. This is the detection terminal and the VI will not switch unless a signal is detected on this line.
- Check the input device to ensure it is working properly.
- Increase the sensitivity by turning the SENSE clockwise (see *Adjusting the VI* section).

VI does not return to Video A

- Check that the input device on the Video B is turned off.
- Check for improper adjustment of the DELAY and SENSE (see *Adjusting the VI* section).

Specifications

Power Input

- 12 Vdc, 100mA
- (110 VAC wall adapter supplied)
- (International adapters available)

Sensing Impedance

- 50,000 ohms minimum

Signal Sensitivity

- Adjustable to allow for system noise

Switching Time - Video A to Video B

- 0.1 seconds

Return Time - Video B to Video A

- Adjustable from 2 to 35 seconds

Priority

- A signal on the Video B terminal will always override a signal on the Video A terminals.

specifications subject to change without notice.

Installation Instructions

for

VI-2 and VI-3 Automatic Audio/Video Switch

R.F. Systems Inc.

Precautions

- Operate the unit only on 120 Vac, 60 Hz.
(see *DC Operation of VI* section for 12 Vdc installations)
- Should any liquid fall into the cabinet, unplug the unit and dry thoroughly before operating again. Failure to dry the unit thoroughly may result in electrical shock.
- Before making any connections, be sure to unplug the unit making sure that all the input and output devices are turned off.

A Word About the VI Operation

The VI is an automatic A-B switch that allows the connection of two audio or video devices to a single output device. The device connected to the Video A terminals is considered the default and the device on the Video B terminals is considered the priority. When there is not a signal coming from the device on the Video B terminals, the VI will connect the Video A terminals to the Video Out terminals. When a signal is detected on the Video B terminal, the VI will disconnect the Video A and connect the Video B terminals to the Video Out terminals. When the signal on the Video B terminals disappears, the VI will switch back to its default position.

Installation Notes

- The power cord should be the last item connected.
- The VI is designed for line and pre-amp level switching. Exceeding this limit may result in permanent damage to the unit.
- The VI senses the switching signal on the Video B line. When this signal is detected the unit will switch from Video A inputs to Video B inputs. When this signal is no longer present, the unit will return to the Video A inputs.
- The VI has a delay and sensitivity adjustment that can be set for your particular installation. Please read *Adjusting the VI* section for more information.

Connecting the VI-2 and VI-3

The VI-2 has standard phono jacks that is compatible with most equipment. Connect the output terminals of the device to the appropriate terminal on the VI-2. It is recommended to always connect the most used device to the Video A inputs. This will result in less switching by the VI. For example: if you use your CD Player every day, and your tape deck once a month, connect the CD Player to the Video A inputs and the tape player to the Video B inputs.

The VI-3 is designed for switching S-VHS signals. The VI-3 senses only the presence on a video signal, therefore it is not recommended to use the VI-3 for switching strictly audio signals.

The following illustrations show some of the most common configurations. Notice that a Y connection is used in many cases to allow a single output to be connected to several devices.

If you plan to use the VI for switching signals from a pre-amp and video surround processor into a single amplifier, you can use the video signal to activate the VI. This will guarantee that the VI will remain activated until the movie is over.

NOTE:

It is very important that neither input device is connected to the Video Out terminals of the VI. Care must be taken to ensure that this is prevented. Failure to do so may result in damage to one or both of the input devices.

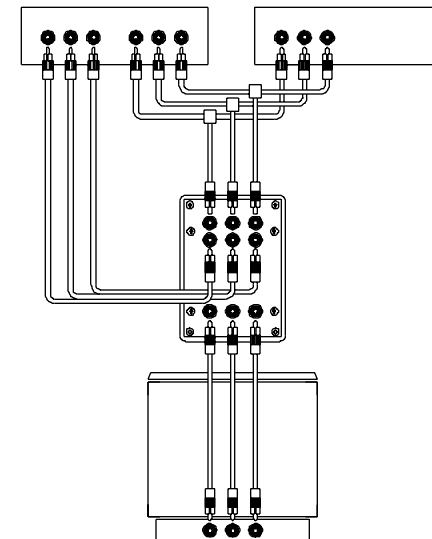
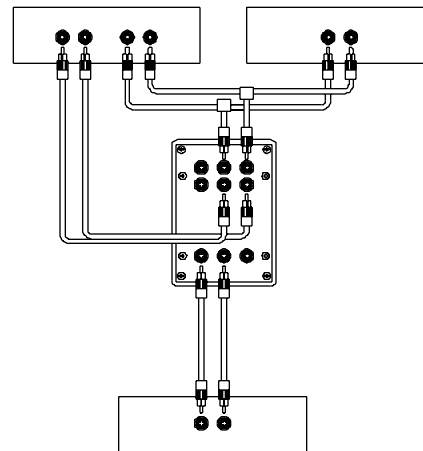

Adjusting the VI

The DELAY and SENSE adjustments on the VI allow the unit to be set for maximum performance even in noisy installations. This noise can be caused by many electrical conditions from poor wire to lightning storms.

Adjusting the Sensitivity

The VI is very sensitive to a signal on the sensing terminals. A small noise signal can cause the unit to erratically switch between inputs for no apparent reason. The SENSE adjustment allows the VI to be set so it will not switch on noise but only on a signal from the source. When the unit arrives it will be set for middle sensitivity. Use a small screwdriver and adjust the SENSE, through the hole in the front panel, clockwise to decrease and counter-clockwise to increase. Only adjust the unit to the point necessary. If you decrease sensitivity to much, the unit may require a stronger signal from the source to activate.

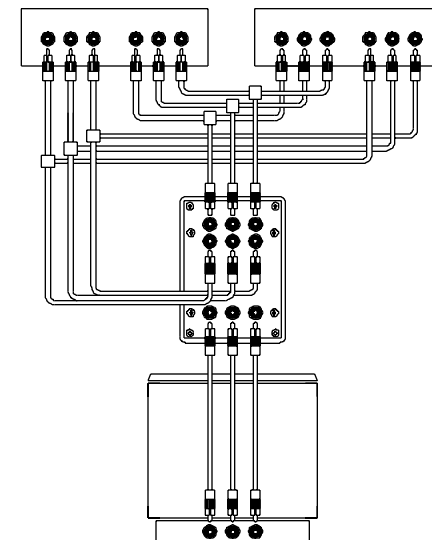

Adjusting the Delay

The Delay adjustment allows a delay on the return time from when a signal has been removed from the Video B terminal and when the VI returns to the default input. The delay adjustment allows the VI to be adjusted for the type of signals to be switched. When using a video signal to switch the VI, it is not usually necessary to have a long delay when returning to the default mode. Using the VI in a home music system requires the VI to delay its return time due to silent passages between tracks and in the music. When the unit arrives, the DELAY will be set for approximately 10 seconds. To adjust, use a small screwdriver and turn the DELAY, through the hole in the front panel, clockwise to decrease the time and counter-clockwise to increase the time.